

KIT PART NUMBER 4751178

INSTRUCTIONS FOR INSTALLING A MUG SWITCH KIT IN A 475 SERIES REFRESHMENT CENTER

CHECK THE PARTS RECEIVED IN THE KIT WITH THE PARTS LIST IN THESE INSTRUCTIONS. IF ANY PARTS ARE MISSING, CONTACT NATIONAL VENDORS' PARTS DEPARTMENT IMMEDIATELY.

Read these instructions carefully before installing the kit.
Keep these instructions for part numbers and for future reference.

This kit contains the following:

INDEX	PART NUMBER	DESCRIPTION	QUANTITY
1	4761099	IC Assembly (U11)	1
2	4751171	Cup Deflector	1
3	4751175	Switch Cover	1
4	4751185	Switch	1
5	3103135	Screw #2-56 x 0.375	2
6	6152135	Nut #2-56	2
7	6203128	Locking Bar	1
8	6232061	Label	1
9	6203127	Pivot Bar	1
10	3157060	Screw #8-32 x .31	3
11	4751184	Wiring Harness	1
12	1452139	Cable Clamp	2
13	4751179	Installation Instructions	1
14	2204513	Wire Tie	1

INSTALL THE MUG SWITCH KIT PER THE FOLLOWING STEPS:

1. Unplug the merchandiser before doing the following steps.

Refer To Figure 1.

2. Remove cup delivery compartment from the merchandiser.
3. Index numbered items are replacement parts provided in this kit. Replace existing parts with these new items. Use original screws and wingnuts to secure new parts. Be sure that the deflector and actuator assembly moves freely. To adjust the assembly, loosen the wing nuts and adjust the position.

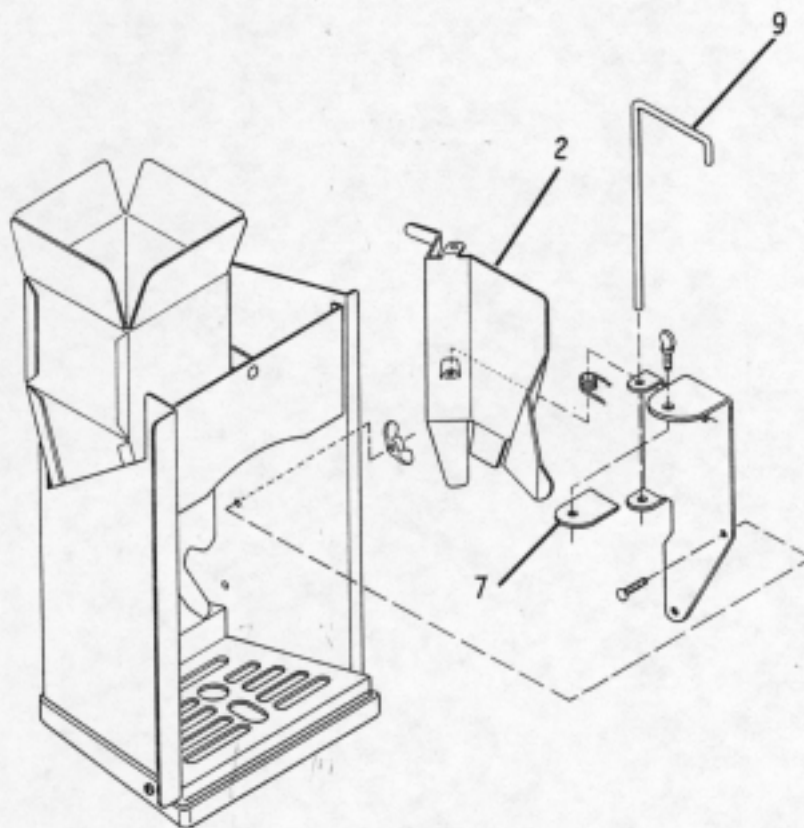

Figure 1. Mug Switch Replacement Parts For Cup Delivery Compartment

Refer To Figure 2.

4. Cut out the template from the last page of these instructions.
5. Fold the template as shown, and fit into the cup station mounting bracket.
6. Drill three (3) 9/64" holes as shown.
7. Assemble the switch (4) to the switch cover (3) with screws (5) and nuts (6). Attach the switch/switch cover assembly to the cup station mounting bracket with screws (10).
8. Attach the mug switch harness to the bracket with cable clamp (12) and screw (10).
9. Plug the connector on the mug switch into the connector on the harness (11).

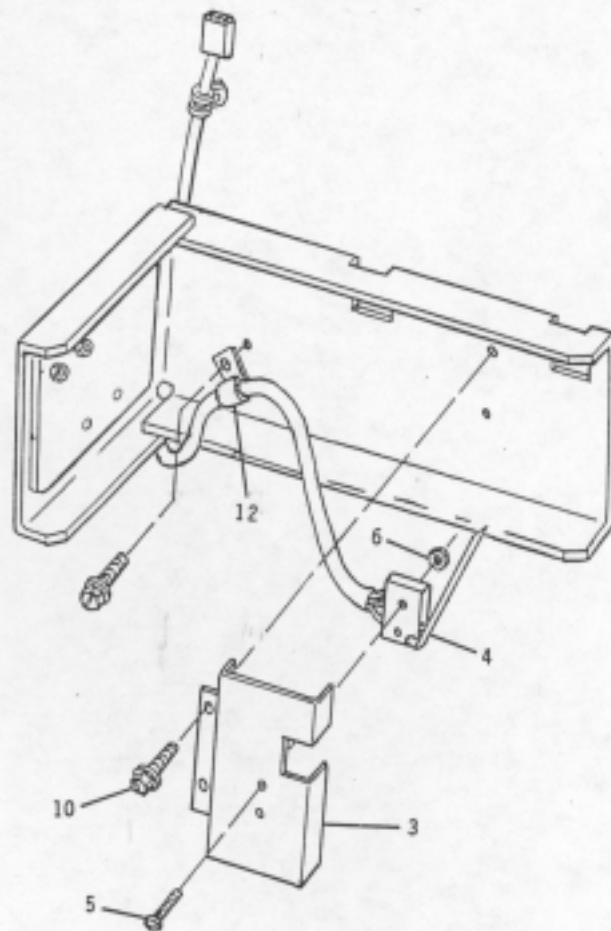

Figure 2. Mug Switch Bracket Assembly Installation

Refer To Figure 3.

- 10 Install mug switch harness (11) and route as shown on Figure 3. Install cable clamp (12), using existing screws and wire tie, in the locations shown on Figure 3.
11. Remove the hot drink controller cover and hot drink controller card.

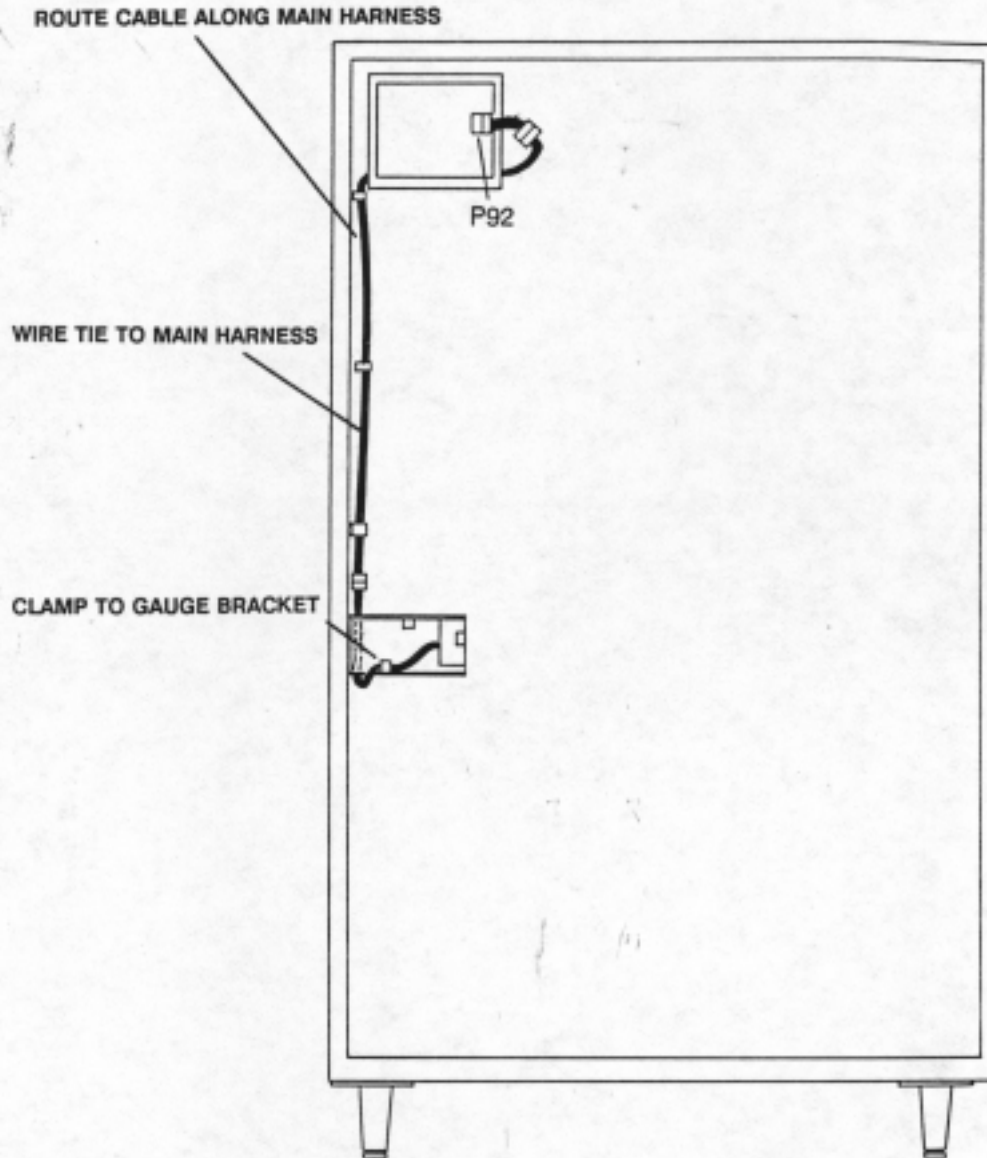

Figure 3. Mug Switch Harness Location

Refer To Figure 4.

12. Disconnect the female plug from P92 on the hot drink controller card and connect it to the male plug at the end of the harness.
13. Connect the female plug on the end of the harness to P92 on the hot drink controller card.

CAUTION

Observe electrostatic discharge precautions during the following steps to avoid damaging equipment.

14. Remove IC U11 from controller card.
15. Install new U11 (1) into the controller card as follows:

Be sure that the notch on U11 is facing in the same direction as shown on Figure 4.

Position U11 on the socket so that each pin is in its corresponding hole.

CAUTION

Take care not to bend the pins on U11.

Using even pressure all around, push U11 into its socket.

16. Replace the controller card and controller card cover.
17. Plug in and turn on the merchandiser. Check to see that the mug switch operates properly. If adjustments are needed, bend the finger on the back of the deflector and actuator assembly until it actuates the switch properly.

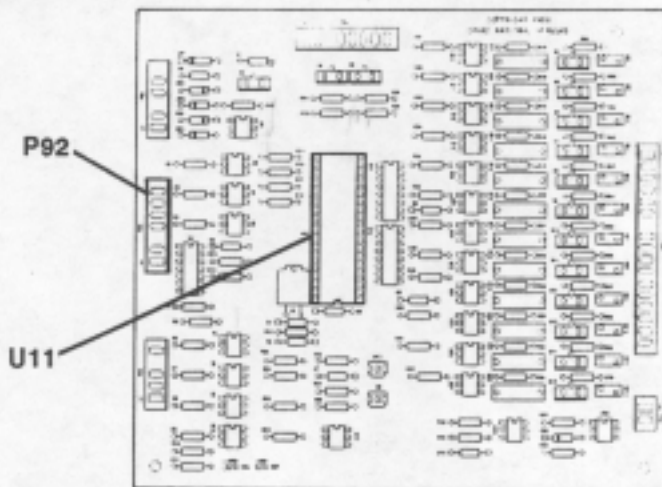

Figure 4. Hot Drink Controller Card Component Location

**CUT OUT
ON SOLID
LINES**

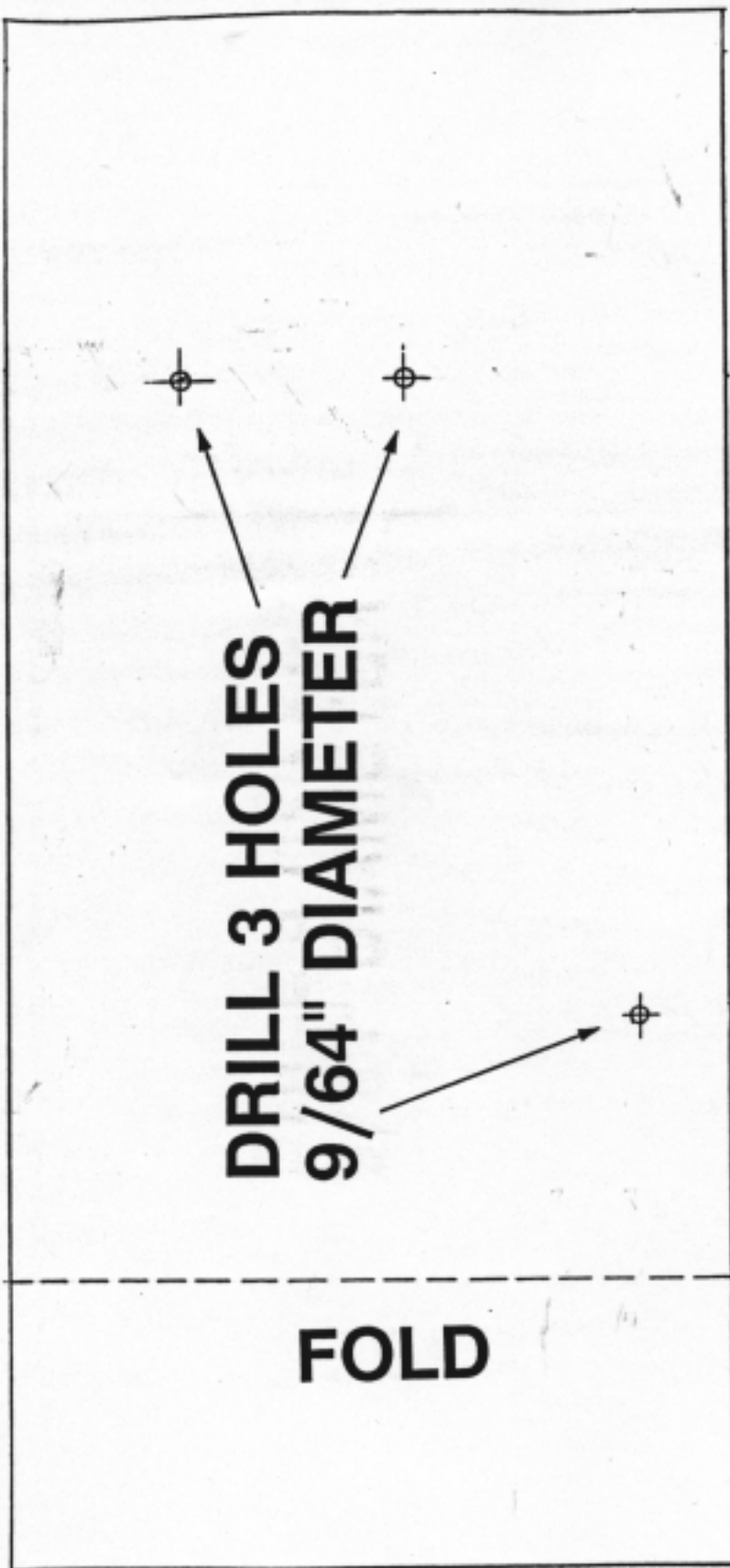

Figure 5. Drilling Template